

Drawer Unit

Cnem-tecn

- **Manufacturing Material:** The manufacturing material used is galvanized sheet metal coated with electrostatically applied paint, with a thickness of 1 millimeter or stainless steel.
- **Body:** Galvanized sheet metal coated with electrostatically applied paint.
- **Doors:** Galvanized sheet metal coated with electrostatically applied paint, consisting of two layers.
- **Handles:** Stainless steel handles.
- **Door hinges:** Soft close hinges, manufactured by Tarka.
- Number of drawers: 4 drawers.
- **Drawer slides:** Soft close slides, manufactured by Tarka.
- **Bases:** The bases are equipped with levelers for weight adjustment of the units.

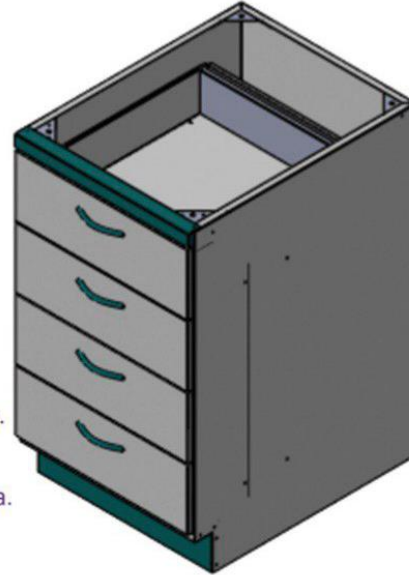

Unit Dimensions:

- Width: 50 cm
- Depth: 65 cm
- Height: 88 cm
- Height of each drawer: 17.5 cm

