

ANGLE

Manufacturing Material: The manufacturing material used is galvanized sheet metal coated with electrostatically applied paint with a thickness of 1 millimeter.

Body: Galvanized sheet metal coated with electrostatically applied paint.

Doors: Galvanized sheet metal coated with electrostatically applied paint, consisting of two layers.

Handles: Stainless steel handles.

Door hinges: Soft close hinges, manufactured by Tarka.

Bases: The bases are equipped with levelers for weight adjustment of the units.

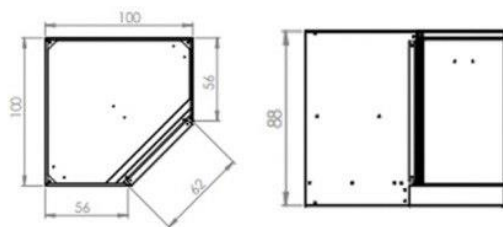
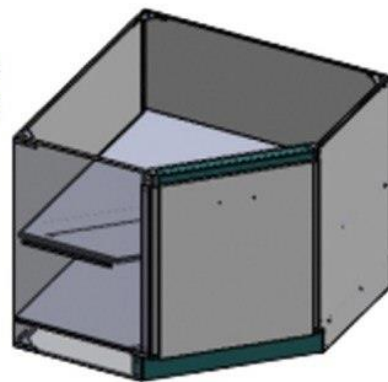

Unit Dimensions:

Width: 100 cm

Height: 88 cm

Depth: 65 cm